

SMART EVO FLEX TONE

12V

NL | Raadpleeg de handleiding van de transformator en kabel voorafgaand aan de installatie van dit armatuur | Gebruik dit product alleen binnen het in-lite systeem. Wanneer in het systeem componenten worden gebruikt die niet van in-lite afkomstig zijn, vervalt het recht op garantie | Monteer de componenten van het in-lite systeem (armaturen, transformators, mini-connectors, Easy-Locks en kabelverbinders) zodanig dat zij altijd vervangen kunnen worden | Gebruik de in-lite laagspanningskabel nooit in combinatie met 100-240V. Deze is alleen geschikt voor het gebruik in combinatie met de onderdelen van het in-lite 12 volt laagspanningssysteem.

EN | Read through the manual for the transformer and cable before installing this fixture | This product may only be used within the in-lite system. If components are used in the system that do not originate from in-lite, the warranty no longer applies | Install the in-lite system components (fixtures, transformers, mini-connectors, Easy-Locks and cable connectors) so that they can easily be replaced | Never use the in-lite low-voltage cable in combination with 100-240V. This is only suitable for use with the components of the in-lite 12 volt low-voltage system.

DE | Beachten Sie die Bedienungsanleitung für den Transformator und das Kabel, bevor Sie mit der Montage dieser Lampe beginnen. | Verwenden Sie dieses Produkt nur in einem in-lite-System. Wenn im System Komponenten verwendet werden, die nicht von in-lite stammen, verfällt der Garantieanspruch | Montieren Sie die Komponenten des in-lite-Systems so (Lampen, Transformatoren, Mini-Verbinder, Easy-Locks und Kabelverbinder) so, dass sie jederzeit ersetzt werden können | Verwenden Sie das in-lite Niederspannungskabel nicht in Kombination mit 100-240V. Es ist nur für die Verwendung in Kombination mit Teilen des in-lite 12-Volt-Niederspannungssystems geeignet.

NO | Se bruksanvisningen for transformatoren og kabelen før denne lampen installeres | Dette produktet må bare brukes i forbindelse med in-lite systemet. Hvis det benyttes komponenter i systemet som ikke kommer fra in-lite, forfaller retten til garanti | Monter komponentene i in-lite systemet (lamper, transformatorer, minikontakter, Easy-Lock og kabelskjøtere) slik at de alltid kan skiftes | Lavspenningskabelen fra in-lite må aldri brukes til 100-240 V. Den er kun egnet til bruk sammen med delene fra in-lite 12 volt lavspenningssystem.

SE | Läs bruksanvisningen till transformatorn och kabeln innan du installerar armaturen | Använd bara denna produkt i kombination med in-lite-systemet | Om komponenter används i systemet som inte kommer från in-lite, förfaller garantin | Montera alltid komponenterna i in-lite-systemet (armaturer, transformatorer, mini-connectors, Easy-Locks och kabelkopplingar) så att man lätt kan komma åt dem | Använd aldrig lågspänningskabeln i kombination med 100-240 V | Den är endast lämplig för användning i kombination med ett lågspänningssystem på 12 V.

FR | Consultez le manuel du transformateur et du câble préalablement à l'installation de cette armature | Utilisez ce produit uniquement au sein du système in-lite. Lorsque des composants non d'origine in-lite sont utilisés dans le système, tout droit à garantie devient caduc | Montez les composants du système in-lite (armatures, transformateurs, mini-connecteurs, systèmes Easy-Lock et raccords de câble) de manière à ce qu'ils puissent toujours être remplacés | N'utilisez jamais le câble basse tension in-lite en combinaison avec le 100-240 V. Celui-ci convient uniquement pour l'utilisation en combinaison avec les composants du système basse tension 12 volts in-lite.

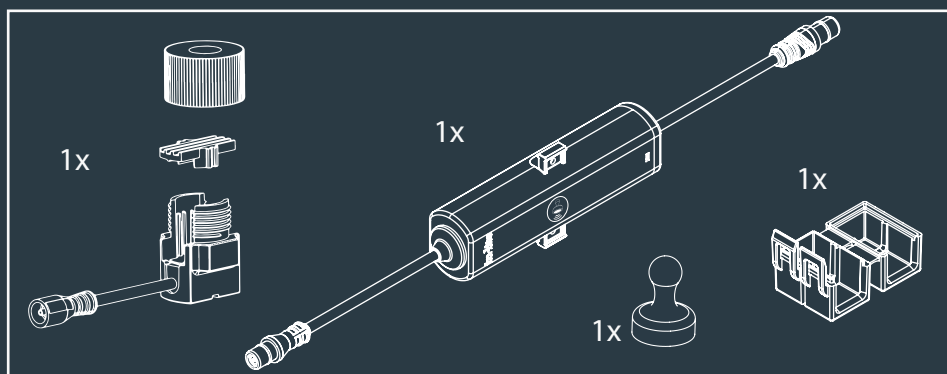

SMART DRIVER 1 TONE

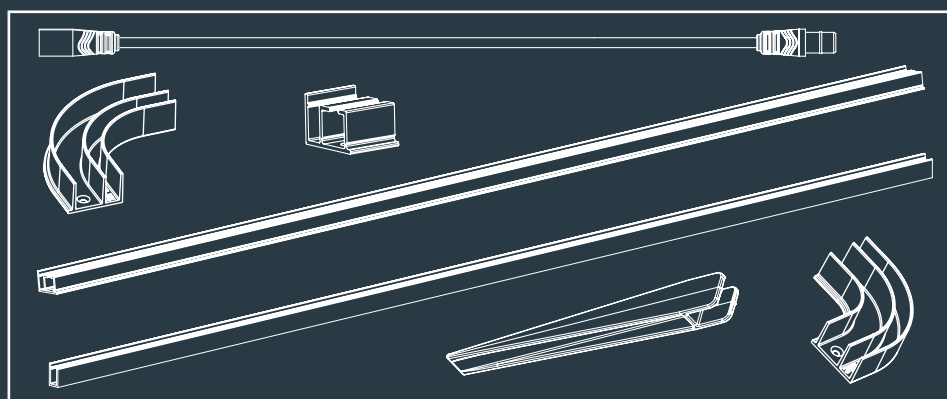

ACCESSORIES

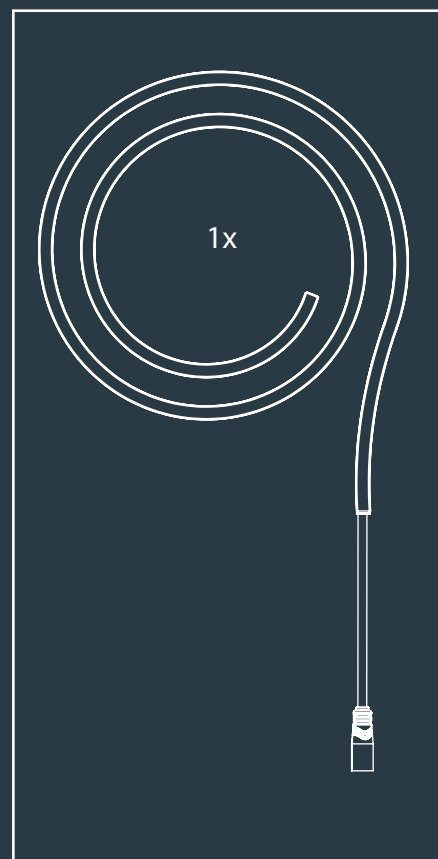

SMART EVO FLEX TONE

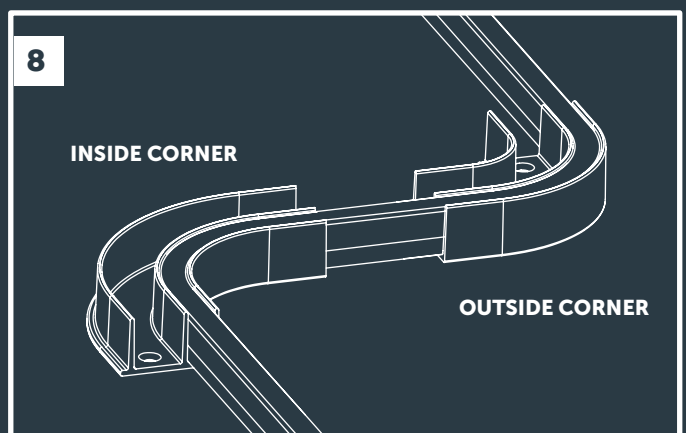
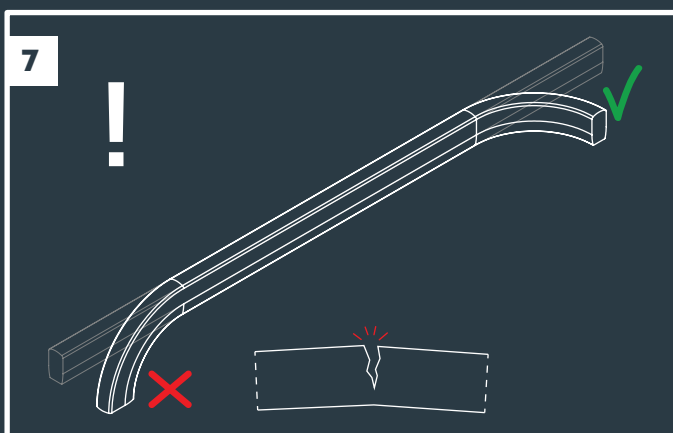
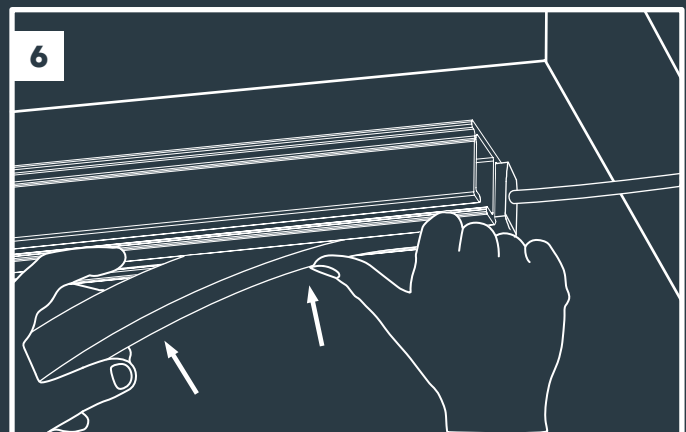
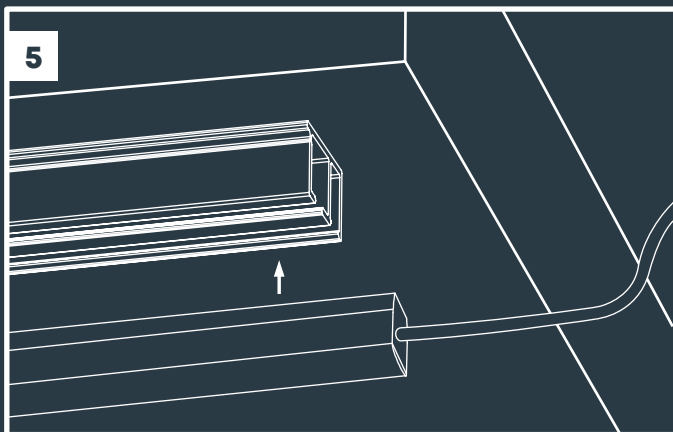
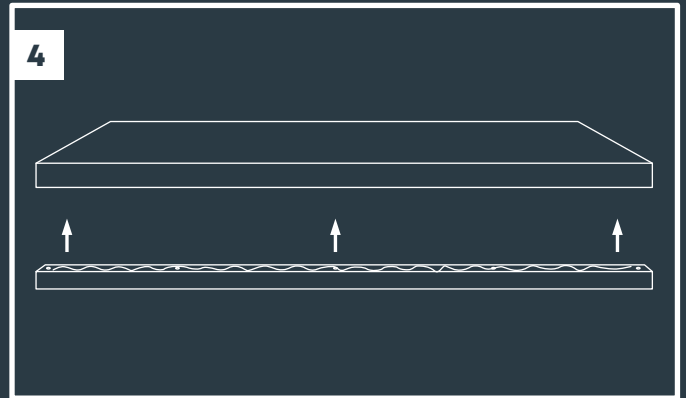
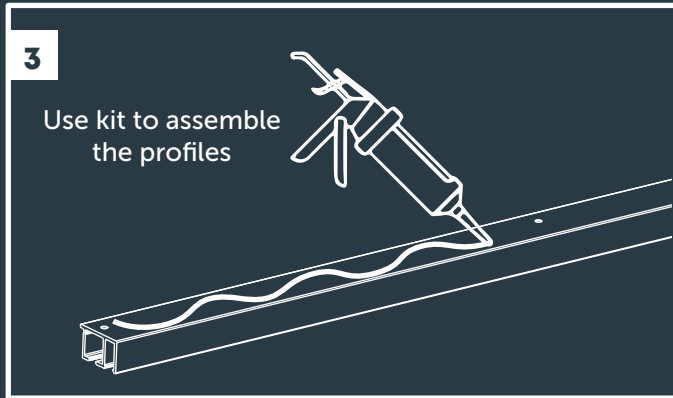
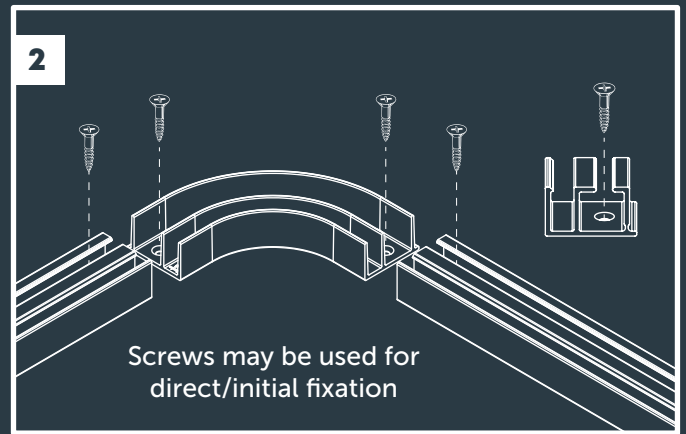
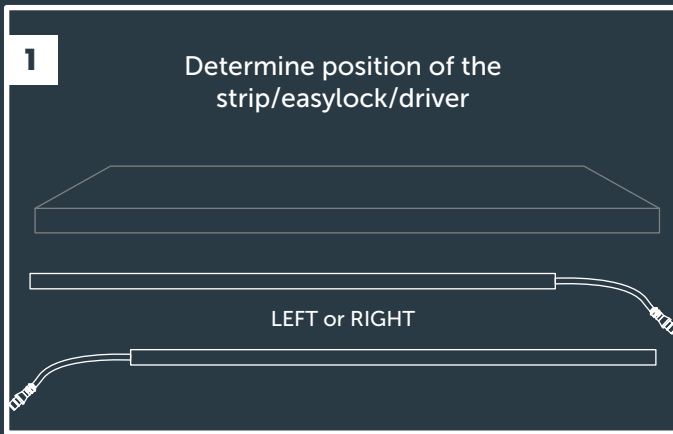

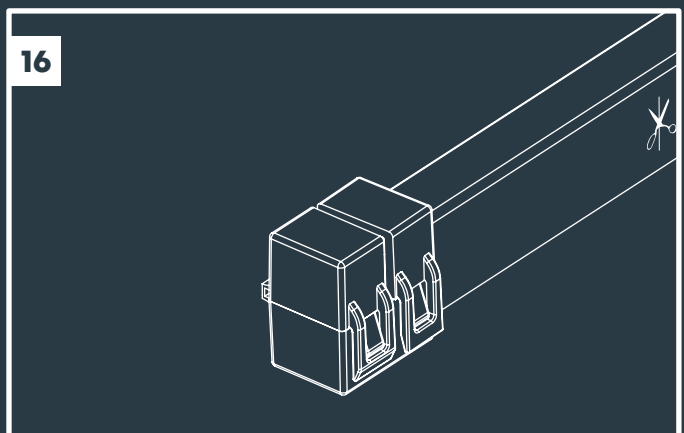
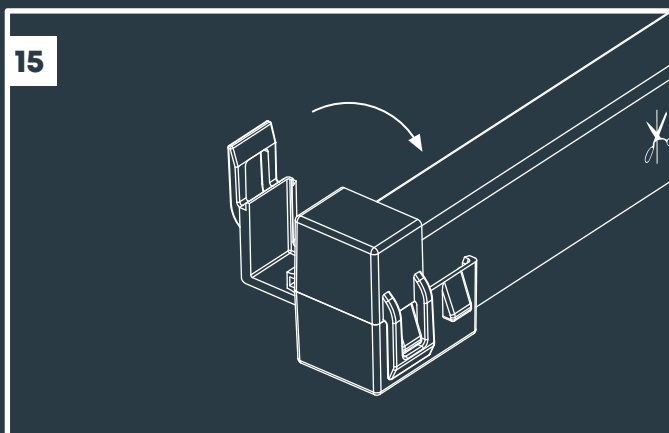
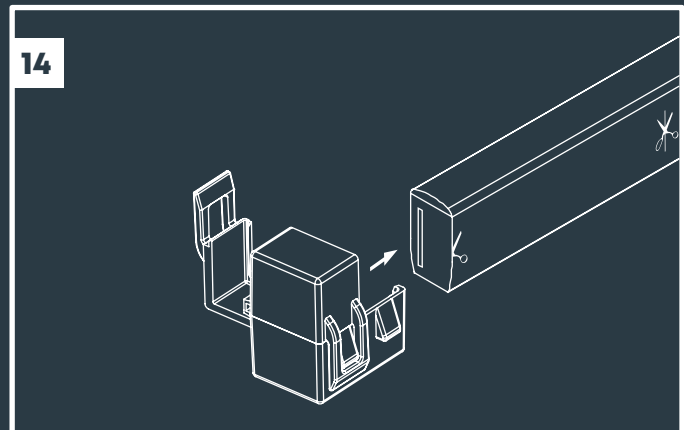
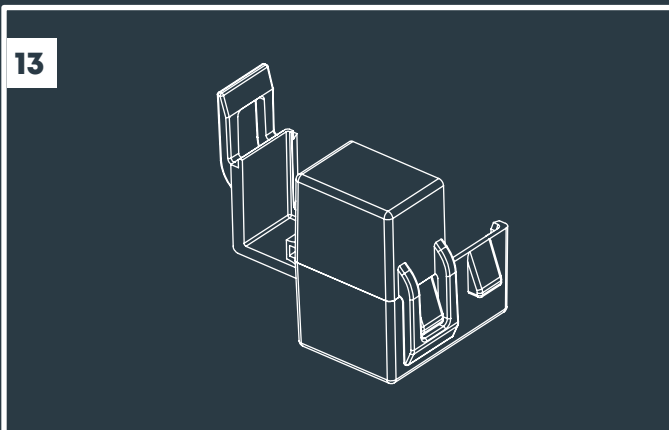
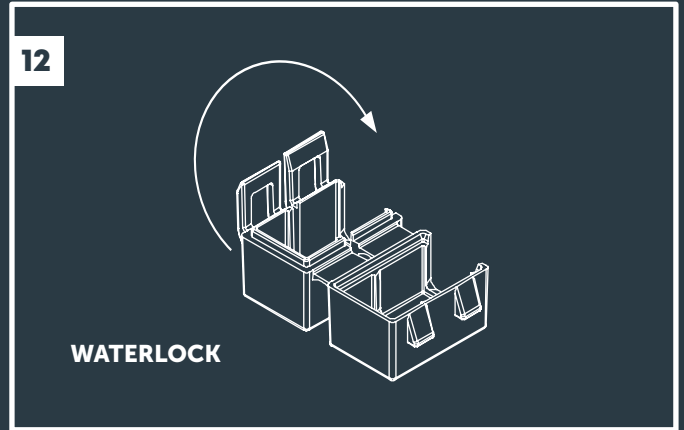
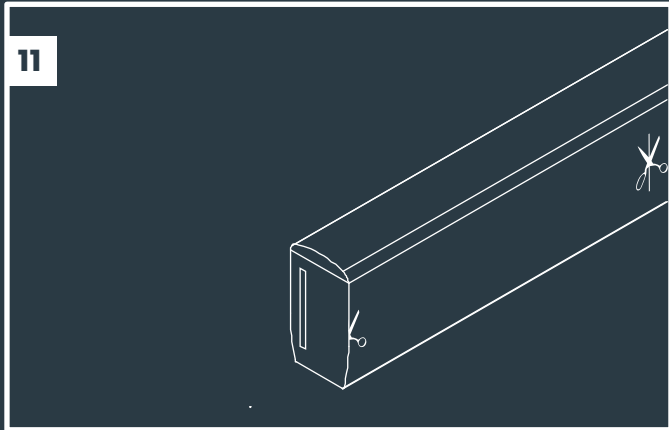
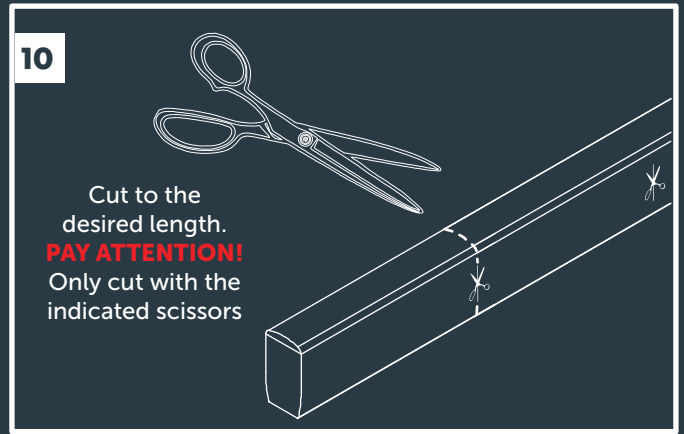
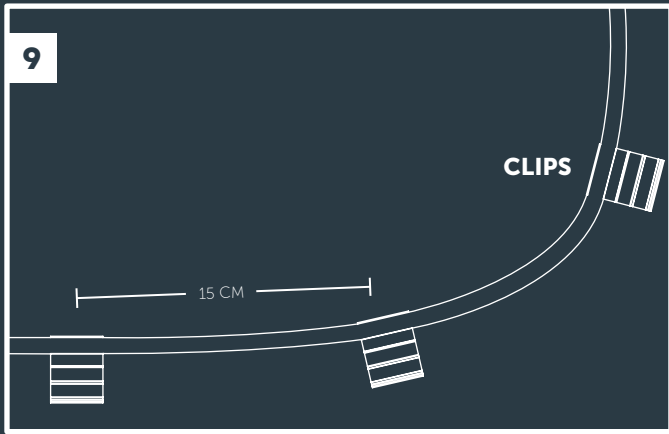

WIDE E D FLEX D IVER

There are different ways to hide the E O FLEX DRIVER. See which one suits your situation best.

SMART DRIVER 1 TONE → SMART E O FLEX TONE



K C D D

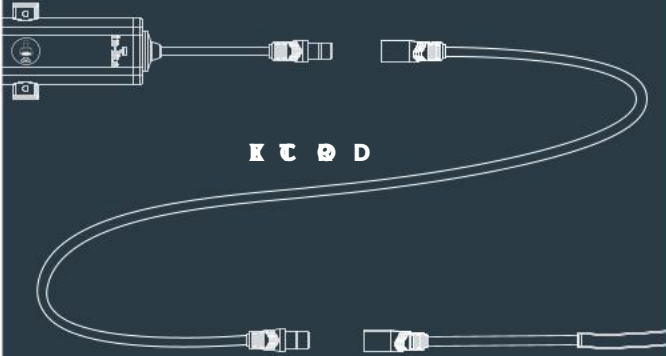

R OFILE

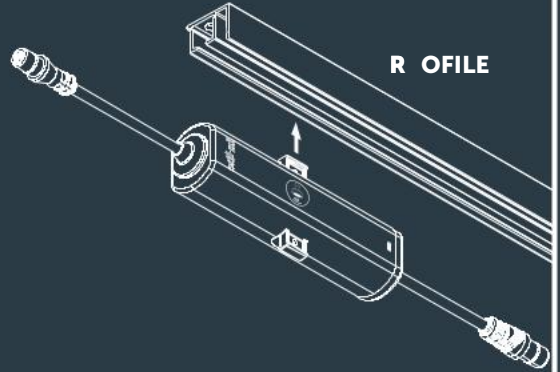

WALL ALIGNED

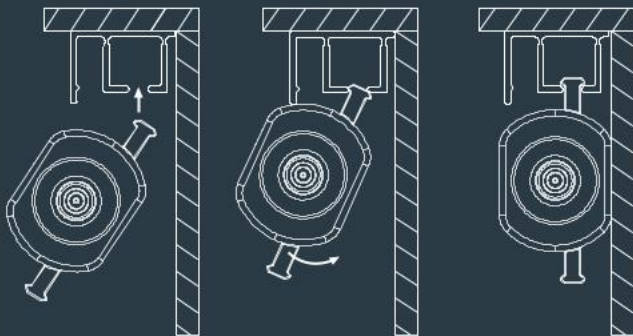

FLEX ALIGNED

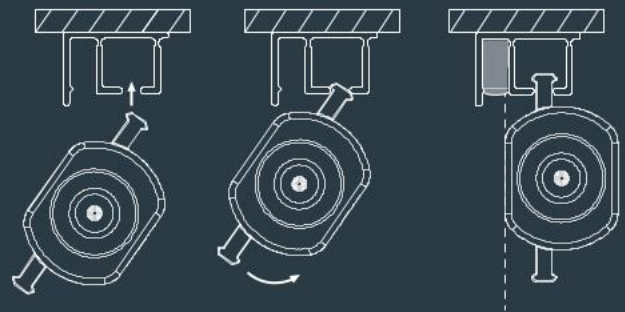

Cable tray
optional

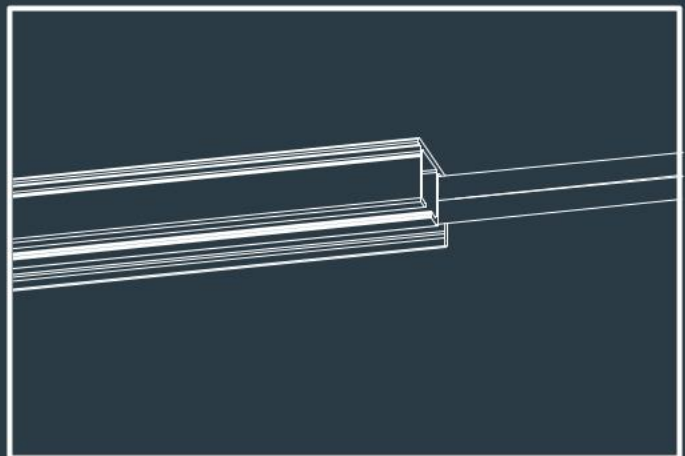
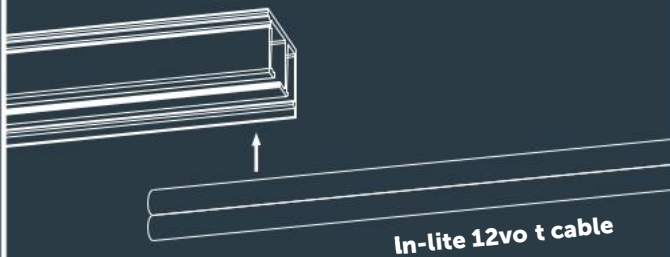

in-lite

APP INSTALLATION

Open the in-lite app
Go to Settings -->
Garden -->
Smart lights

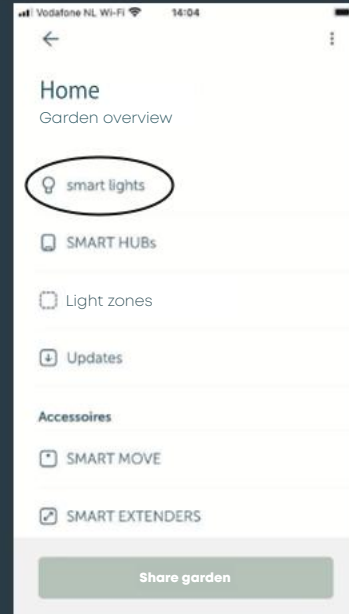

Finish installation
in the in-lite app



OPTIONAL:
Reset the SMART EVO FLEX TONE

Magnet position

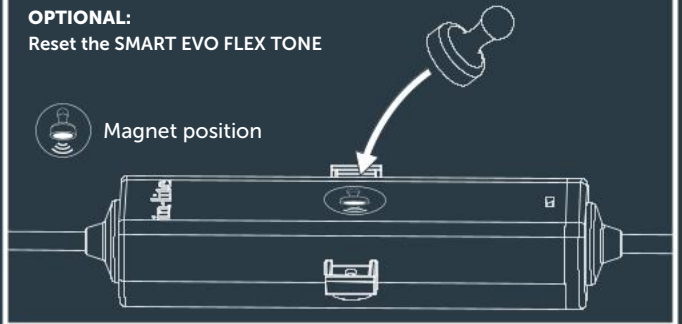

- EVO FLEX blinks blue 1x
- Hold the magnet in position
- EVO FLEX flashes a blue light repeatedly

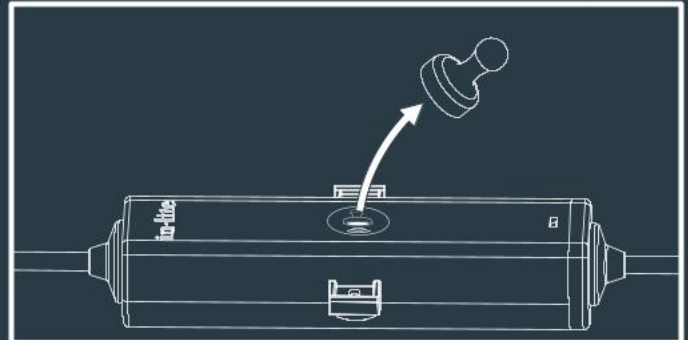
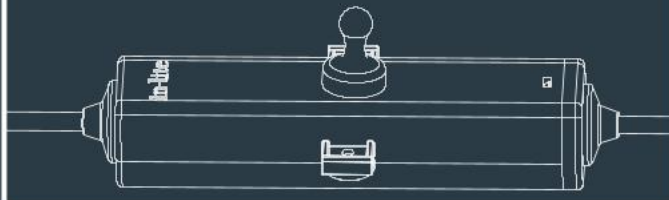

GEBRUIKERSTIPS

ALLEEN HORIZONTAAL TE BUIGEN,
NIET TE SCHERP (MAX. RADIUS 3CM)

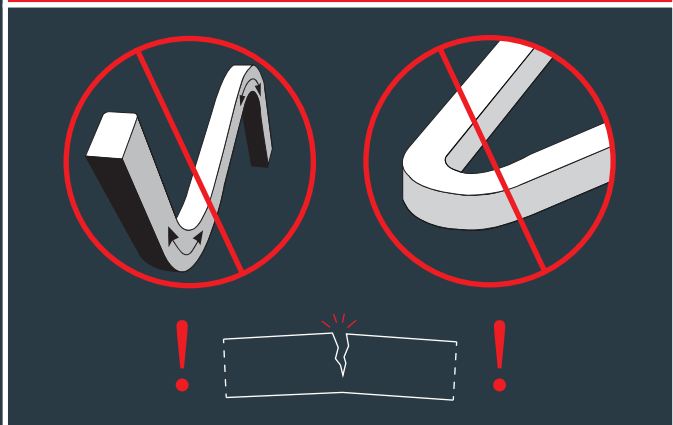

VOORZICHTIG MET TWEE HANDEN
VERWIJDEREN UIT HET PROFIEL

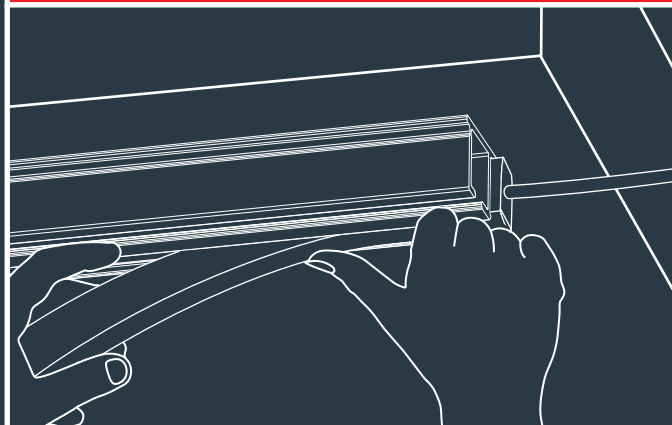

ALLEEN INKORTEN OP AANGEGEVEN LIJN EN
VOORAFGAAND CHECKEN OF DE STRIP WERKT

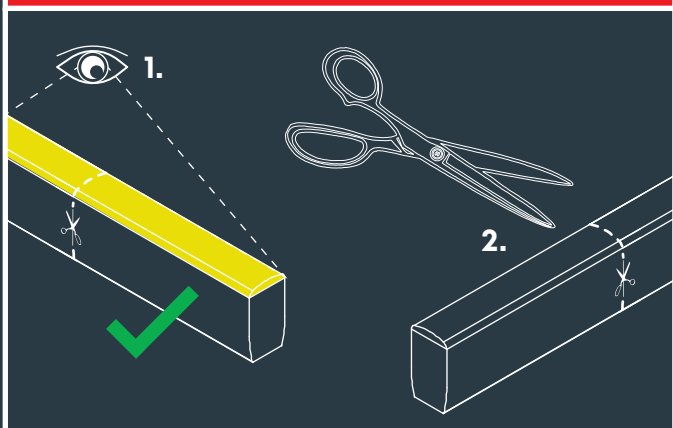

NOOIT INKORTEN ALS DE
EVO FLEX AAN STAAT

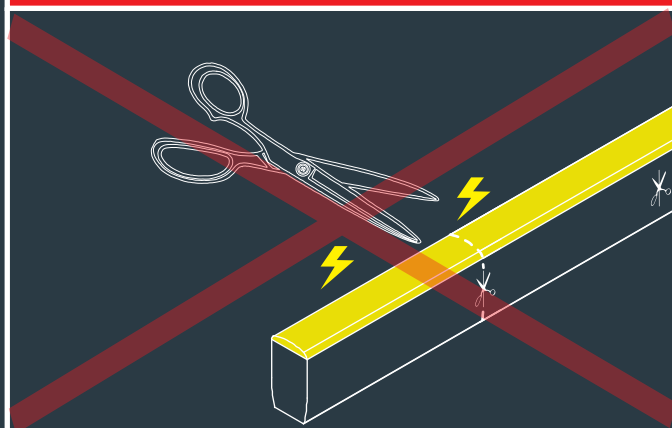

NA KNIPPEN EVO FLEX ALTIJD VOORZIEN
VAN MEEGELEVERDE WATERLOCK

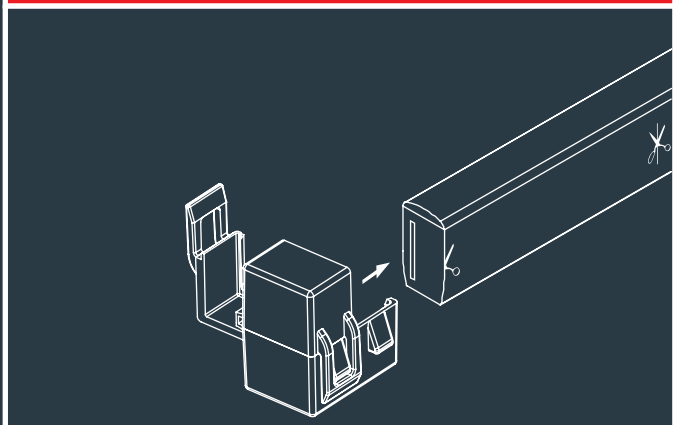

PLAATS ALTIJD EEN DRIVER I.C.M. DE EVO FLEX

